

Comparison Chart of Flow Rates

The flow rates of our coupling systems are summarized in the following chart.

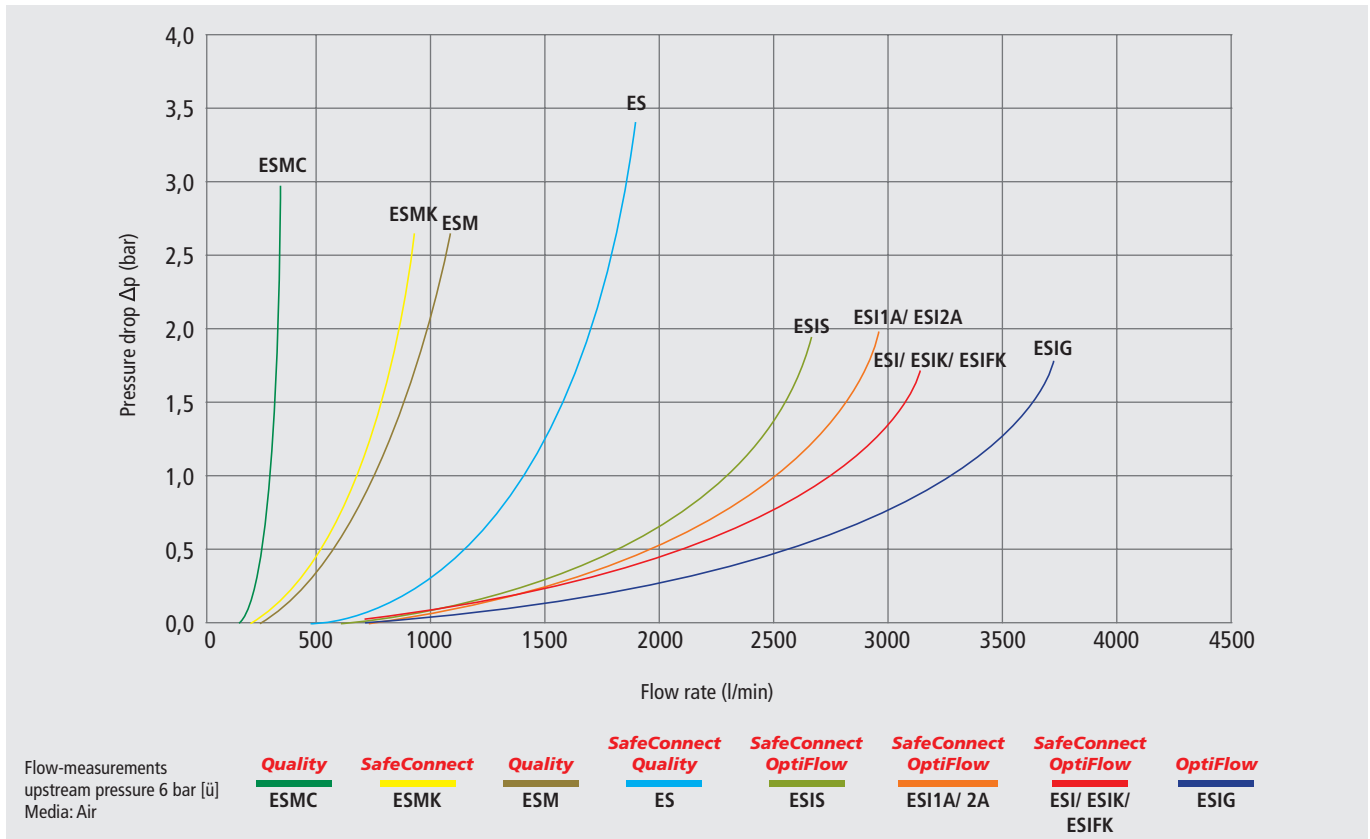

Testing Panel

To train and thoroughly test our quick connect couplings, we developed Testing Panels. These sample bars represent the quick connect coupling series from DN 2.7 up to DN 10 of our **Quality**-, **OptiFlow**- and **SafeConnect-Line** as well as the MODY spiral hoses under pressure.

Your advantages:

- Extensive information about each product and how they work
- Testing high-quality products under real life conditions (the coupling procedure may be executed with media passing through the lines)
- Multilingual: German and English (on request, also in other languages)

Product Information

Functional Description

Application Possibilities (coupling)

Compressed Air Connection

LUEDECKE Since 1930. The perfect connection.

TESTING PANEL Pneumatics

Quick Connect Couplings with Standard Plug Profiles

To supply compressed air in industry and craftsmanship, pneumatic, measurement, control and regulation technique

Series	ESMC	ESM	ES	ESIS	ESIG
Size	DN 2.7	DN 5	DN 7.2	DN 7.8	DN 10

LUEDECKE MADE IN GERMANY

Pressure of the panel is reduced to 3 bar for safety

We offer the testing panels at cost price.
If you are interested please contact our expert sales team.

Overview of Quick Connect Couplings with

Quality-Line

OptiFlow-Line

Series

ESMC
DN 2.7

ESM
DN 5

ES
DN 7.2

ESI
DN 7.8

ESIS*
DN 7.8

ESIG
DN 10

ESG
DN 19

Plug Profile
(original size)

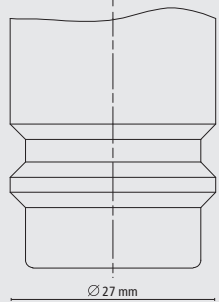
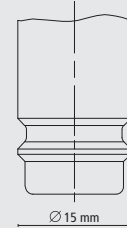
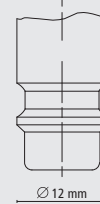
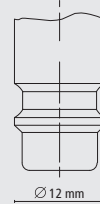
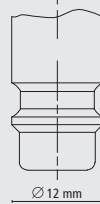
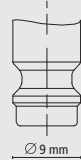

Materials:							
Body:	MS 58 (plain/n-plated)	MS 58 (plain/n-plated)	MS 58 (plain/n-plated)	MS 58 nickel-plated	MS 58 nickel-plated	MS 58 nickel-plated	MS 58 plain
Sleeve:	MS 58 (plain/n-plated)	MS 58 (plain/n-plated)	MS 58 (plain/n-plated)	Steel hardened + nickel-pl.	Steel hardened + nickel-pl.	Steel hardened + nickel-pl.	MS 58 plain
Valve Body:	MS 58 (plain/n-plated)	MS 58 (plain/n-plated)	MS 58 (plain/n-plated)	MS 58 nickel-plated	MS 58 nickel-plated	MS 58 nickel-plated	MS 58 plain
Valve:	MS 58 (plain/n-plated)	MS 58 (plain/n-plated)	MS 58 (plain/n-plated)	MS 58 plain	MS 58 plain	MS 58 plain	MS 58 plain
Springs, Retaining ring:	Stainless Steel 1.4310	Stainless Steel 1.4310	Stainless Steel 1.4310	Stainless Steel 1.4310	Stainless Steel 1.4310	Stainless Steel 1.4310	Stainless Steel 1.4310
Balls:	Stainless Steel 1.3541	Stainless Steel 1.3541	-	Stainless Steel 1.4034	Stainless Steel 1.4034	Stainless Steel 1.4034	Stainless Steel 1.4034
Pins:	-	-	Stainless Steel 1.4305	-	-	-	-
Seals:	NBR	NBR	NBR	NBR	NBR	NBR	NBR
Special seals for other media on request:	EPDM, FKM, FFKM	EPDM, FKM, FFKM	EPDM, FKM, FFKM	EPDM, FKM, FFKM	EPDM, FKM, FFKM	EPDM, FKM	EPDM, FKM, FFKM
Plugs:	MS 58 (plain/nickel-plated)	MS 58 (plain/nickel-plated)/ steel zinc-plated	MS 58 (plain/nickel-plated)/ steel zinc-plated	Steel hardened + nickel-plated	Steel hardened + nickel-plated	Steel hardened + nickel-plated	MS 58 plain
Max. Working Pressure:	PN 35 bar	PN 35 bar	PN 35 bar	PN 35 bar	PN 12 bar	PN 35 bar	PN 35 bar
Temperature:	-20°C – +100°C	-20°C – +100°C	-20°C – +100°C	-20°C – +100°C	-20°C – +100°C	-20°C – +100°C	-20°C – +100°C
Thread types:	ISO 228/ DIN 13	ISO 228/ DIN 13	ISO 228/ DIN EN 10226/ DIN 13	ISO 228/ DIN EN 10226	ISO 228/ DIN EN 10226	ISO 228/ DIN EN 10226	ISO 228
Flow rate: at 6 bar [ü] and 0.5 bar pressure drop single shut-off	165 l/min	510 l/min	1100 l/min	2000 l/min	1800 l/min	3200 l/min	8000 l/min
Type of valve:	single/ double/ straight-through	single/ double/ straight-through	single/ double/ straight-through	single/ double/ straight-through	single	single/ double/ straight-through	single/ double
Operation:	One-Hand	One-Hand	One-Hand	One-Hand	One-Hand	One-Hand	One-Hand
Interchange:	Parker Rectus Series 20	Parker Rectus Series 21	Parker Rectus Series 25/26 Cejn 320	Parker Rectus Series 25/26 Cejn 320	Parker Rectus Series 25/26 Cejn 320	Parker Rectus Series 27/41/1700 Cejn 410	Parker Rectus Series 39 Hansen 7000
Page:	32	37	43	54	68	59	62

European Plug Profiles

SafeConnect-Line

NEW!

ESIS*
DN 7.8

ES
DN 7.2

ESI*
DN 7.8

ESIK*
DN 7.8

ESI1A/2A*
DN 7.4

ESMK
DN 5

ESIFK*
DN 7.8

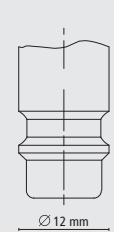
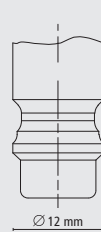
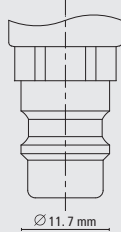
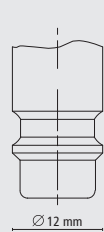
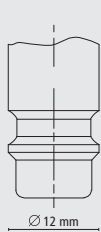
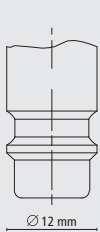

MS 58 nickel-plated	MS 58 plain	MS 58 nickel-plated	MS 58 nickel-plated	MS 58 nickel-plated	MS 58 plain	MS 58 plain
Steel hardened + nickel-pl.	MS 58 plain	Steel hardened + nickel-pl.	Steel hardened + nickel-pl.	MS 58 nickel-plated	Aluminium anodised	Aluminium anodised
MS 58 nickel-plated	MS 58 plain	MS 58 nickel-plated	MS 58 nickel-plated	MS 58 nickel-plated	MS 58 plain	MS 58 plain
MS 58 plain	MS 58 plain	MS 58 plain	MS 58 plain	MS 58 plain	MS 58 plain	MS 58 plain
Stainless Steel 1.4310	Stainless Steel 1.4310	Stainless Steel 1.4310	Stainless Steel 1.4310	Stainless Steel 1.4310	Stainless Steel 1.4310	Stainless Steel 1.4310
Stainless Steel 1.4034	-	Stainless Steel 1.4034	Stainless Steel 1.4034	Stainless Steel 1.4034	Stainless Steel 1.3541	Stainless Steel 1.4034
-	Stainless Steel 1.4305	-	-	-	-	-
NBR	NBR	NBR	NBR	NBR	NBR	NBR
EPDM, FKM, FFKM	EPDM, FKM, FFKM	EPDM, FKM, FFKM	EPDM, FKM, FFKM	EPDM, FKM, FFKM	EPDM, FKM, FFKM	EPDM, FKM, FFKM
Steel hardened + nickel-plated	MS 58 (plain/nickel-plated)/ steel zinc-plated	Steel hardened + nickel-plated	Steel hardened + nickel-plated	MS 58 nickel-plated	MS 58 plain with anodized aluminium ring	MS 58 plain with anodized aluminium ring
PN 12 bar	PN 35 bar	PN 35 bar	PN 35 bar	PN 35 bar	PN 35 bar	PN 35 bar
-20°C – +100°C	-20°C – +100°C	-20°C – +100°C	-20°C – +100°C	-20°C – +100°C	-20°C – +100°C	-20°C – +100°C
ISO 228/ DIN EN 10226	ISO 228	ISO 228/ DIN EN 10226	ISO 228/ DIN EN 10226	ISO 228/ DIN EN 10226	ISO 228	ISO 228
1800 l/min	1100 l/min	2000 l/min	2000 l/min	1800 l/min	430 l/min	2000 l/min
single	single	single	single	single	single/ double	single
One-Hand	One-Hand	One-Hand	One-Hand	Two-Hands	One-Hand	One-Hand
Parker Rectus Series 25/26 Cejn 320	Parker Rectus Series 25/26 Cejn 320	Parker Rectus Series 25/26 Cejn 320	Parker Rectus Series 25/26, Cejn 320 Steinco Series 125	Parker Rectus Series 95/96 Cejn 320	Parker Rectus Series 21	Parker Rectus Series 25 KA
68	69	70	72	74/ 75	76	80
Self-Venting	Sleeve Lock Mechanism			Visual Identification		

* SafeConnect-Line + OptiFlow-Line

OptiFlow-Line

Energy-Efficient Quick Connect Couplings



Compressed air - an expensive media?

Despite many advantages, compressed air has a reputation for being a costly media – in many cases, this is not true. When using the right components, an energy-efficient operation is possible.

Energy performance is reduced by the following:

- Standard valves with large surface area
- Too small dimensioned hose or tubing
- Too small dimensioned connections
- Insufficient capacity in networks or compressed air systems
- Excess humidity

This leads to:

- High pressure drop
- High energy consumption of compressor
- Reduced productivity
- Damages to systems/ tools

The **LUDECKE OptiFlow-Line** offers energy-optimised coupling systems which achieve higher flow rates and significantly reduce energy consumption. This in turn leads to decreasing energy costs as well as increasing durability and lifetime of machines and tools.

By continuously improving our development and production processes, we ensure that our quick connect couplings are permanently revised and performance optimised. In this way, we guarantee sustainable and efficient operation.

Find out more about the **LUDECKE** sustainability strategies in our Green Company Report (www.ludecke.com).

LUDECKE OptiFlow-Line

- Patented OptiFlow by **LUDECKE**® valve technology
- Extremely high flow rates
- Low pressure drop
- High durability
- Great operational safety and best sealing characteristics

Opti[®]
Flow
by **LUDECKE**



Flow Simulation - Comparison

The products of the **LUDECKE OptiFlow-Line** have a valve with optimised geometry for higher flow rates.

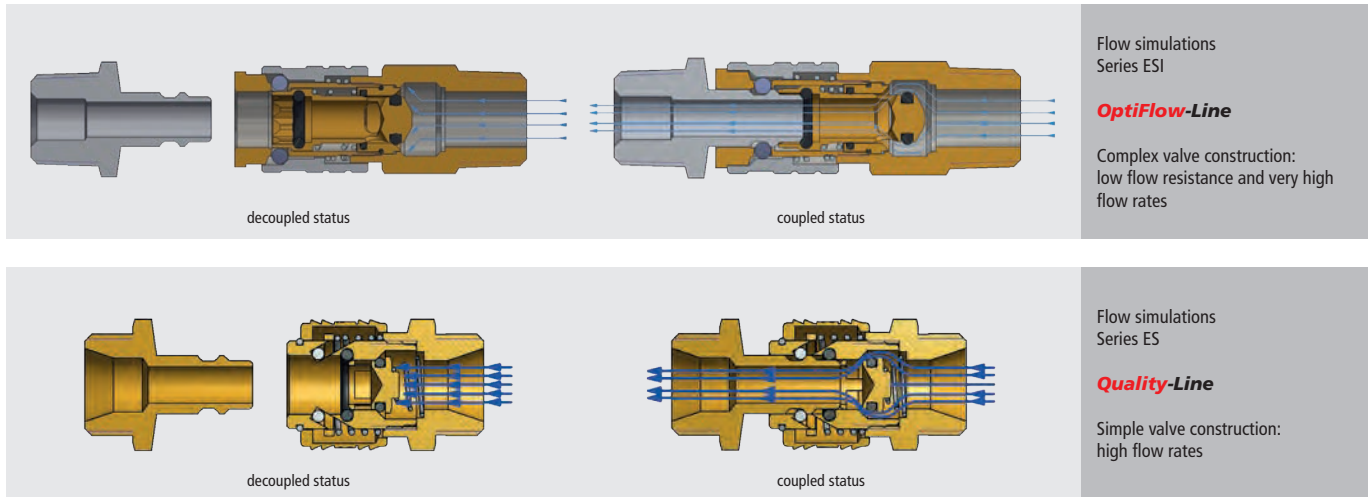

Comparison Chart of Flow Rates

The flow rates of the **LUDECKE OptiFlow-Line** (in comparison to the **Quality-Line**) are summarized in the following chart.

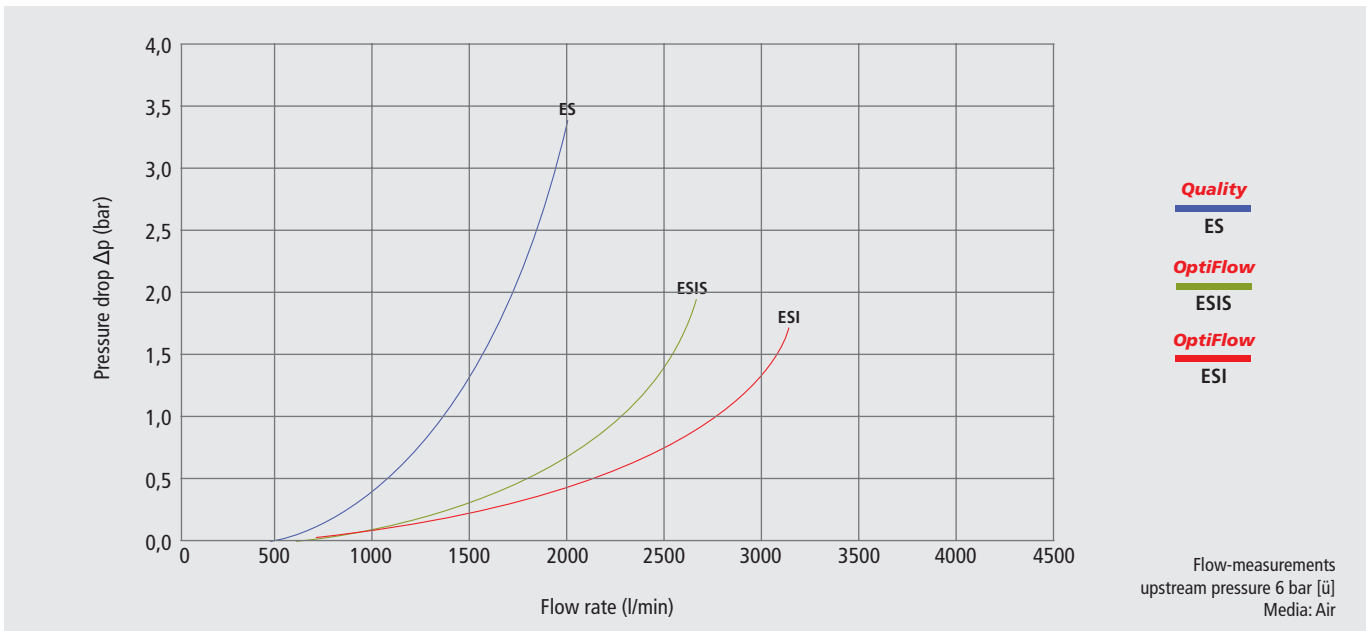

Different Sizes and Versions

The **LUDECKE OptiFlow-Line** is made up of different series.

Industrial Quick Connect Couplings		Industrial Quick Connect Couplings	Safety Quick Connect Couplings				
Series: ESI DN 7.8	Series: ESIG DN 10	Series: ESG DN 19	Series: ESIS DN 7.8	Series: ESI DN 7.8	Series: ESIK DN 7.8	Series: ESI1A DN 7.4 ESI2A DN 7.4	Series: ESIFK DN 7.8